



MadStad Adjustable Windshield Brackets Kawasaki Versys 2007-2009

Installation Instructions

What Is In The Box:

- (1) Set of Pre-Assembled MadStad Adjustable Windshield Mounts with (4) rubber well nuts installed
- (1) Instruction Sheet (this document)
- (1) Hardware Packet, contents as follows:

Mounting Screws

- (4) M6 x 16 Screws
- (4) M6 Flat Washers
- (4) M6 lock nuts
- (4) white shoulder washers

Windshield Screws

- (4) M5 T-Screws with
- (4) plastic flat washers
- (8) hard rubber washers

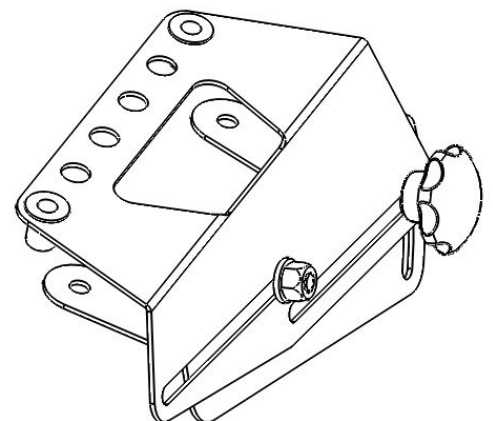
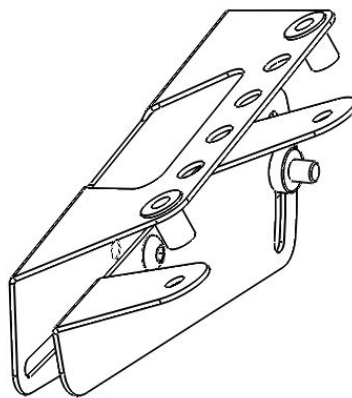

Other

- (1) 4mm Allen wrench

On your current Versys setup:

Remove the stock windshield and the factory rubber well nuts. You will not need the factory windshield screws so store them in a safe place.

MOUNTING THE BRACKETS

The MadStad brackets attach to the top and bottom holes of the windshield mounts on the Versys. First you need to insert a white shoulder washer into each of the four outermost holes. Then lay the MadStad bracket over the shoulder washers and insert an M6 screw through the top of each mounting hole (shown by the dashed lines below), and through the shoulder washers. NOTE: The knob side of the brackets should be up toward the driver.

Slide a flat washer and lock nut onto the bottom of each M6 button head screw and tighten using the provided M4 Allen wrench and a 10mm crescent wrench. You may need to loosen the adjustment knob and slide the brackets in order to access mounting holes. The two brackets installed together should be oriented like the image shown below.

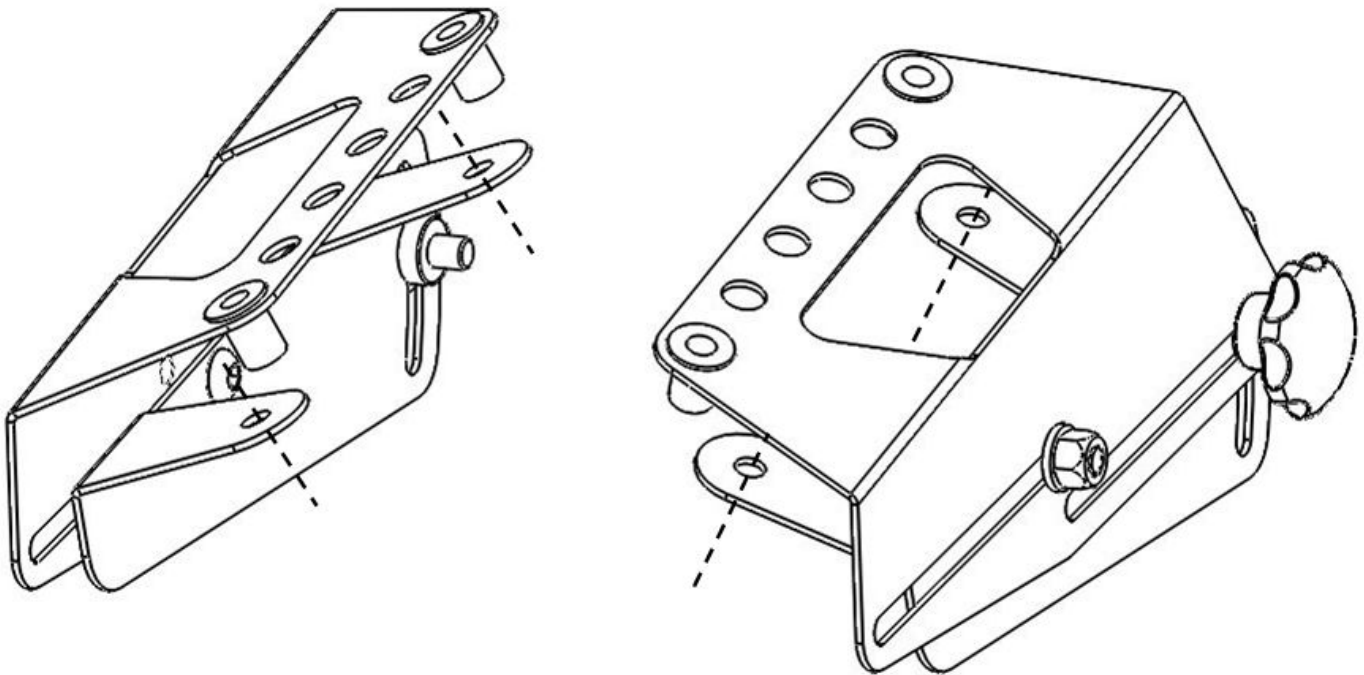

INSTALLING THE WINDSHIELD

You can install the windshield using the T-screws provided in your hardware packet. (see diagram below)

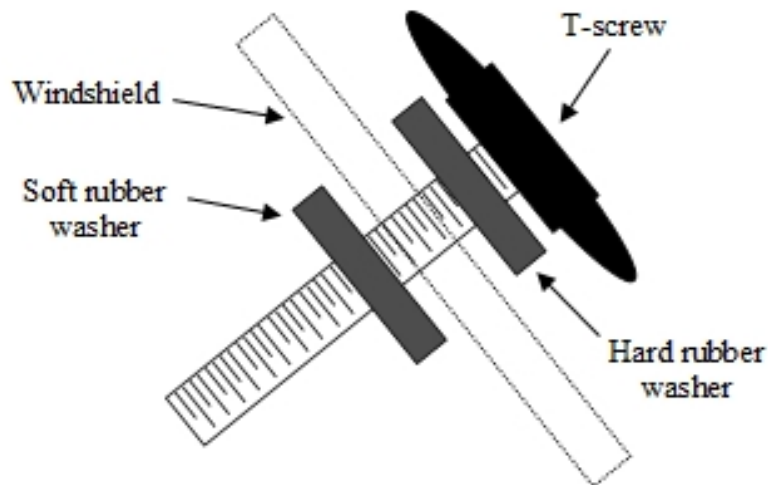

You will probably want to pre-attach all four T-screws and eight washers to your shield before mounting it to the brackets. This will make it easier to get all four screws inserted. The rubber washers on the bottom side will keep the screws from falling out as you handle the windshield.

Screw the shield on until each screw begins to protrude through the bottom of the nut and the nut begins to swell up. At this point the screws are snug enough and do not need to be tightened down hard. **DO NOT OVERTIGHTEN** or you could tear up the well nuts!

PIVOT SCREWS

The MadStad mount has a pivot screw on each set of brackets, located near the middle of brackets. A nylon lock nut keeps the screw in place, yet allows the brackets to slide back and forth. It is adjusted at the factory to have a minimum of play yet still allow the brackets to move. If for some reason you wish to adjust the tightness of this pivot screw, use a 4mm Allen wrench along with a 10mm socket or open-end wrench to make the adjustment. If you tighten the lock nut completely you will not be able to slide the brackets.

ADJUSTMENT KNOBS

To adjust the windshield for height and/or angle you must loosen the knobs about 1-2 turns to loosen the brackets, allowing them to slide back and forth. Gently push or pull on the shield to position it where you want it. Once you have the brackets adjusted, you do not need to tighten the knobs down hard, just snug enough to prevent them from moving out of adjustment.

ADJUSTING THE MADSTAD BRACKETS

The knob screws release the brackets allowing the windshield to slide and tilt. **These knob screws must always be tightened securely before riding!** Please don't ever try to adjust the MadStad brackets while in motion. Always come to a complete stop keeping the bike stable while making adjustments.

INITIAL WINDSHIELD SETTING

When first setting up your MadStad system, the top edge of the shield should be around your chin level as you look over the top. This will give you a good view over the top of the shield while still deflecting the wind pressure up and over your head.

The initial windshield angle should be at approximately 60 degrees and you can check this using the guide on the back page of this manual. You can guesstimate this by setting the angle about the same as your stock shield was, then push the top of the shield forward a bit so that it sits more upright, more vertical. Do not push it so vertical that the bottom of the shield rests against the fairing. You need at least a 1 inch gap between the bottom of the shield and the fairing in order for air to flow smoothly up underneath the shield. This is what gets rid of the vacuum and turbulence that normally forms behind a fixed windshield.

Tighten the knobs and go for a ride to see if you now have smooth airflow over and around your helmet. Do this on a calm day if at all possible; windy days make it hard to judge the airflow. To try a different windshield position, bring the motorcycle to a **complete stop and out of traffic**. Loosen the two knob screws and tilt the windshield forward or back 2-3 degrees or so, and/or adjust it up or down if necessary. Re-tighten the knobs and go for another ride.

Although setting the shield more vertical than stock is usually the best way to get a smooth comfortable airflow, everybody is a little different so you can certainly try angling the shield the same as or farther back than the stock angle. On hot days you may want more air to get through, and angling the windshield back is one way to do that.

WARNING: *If you tilt the shield fully backward, it may make contact with the top edge of the brackets. This could scratch the back of your shield, so please check to make sure there is no contact.*

Continue experimenting with different positions at different speeds until you find a combination of height and angle that eliminates buffeting and gives you a smoother ride. If necessary, raise or lower the entire mount to the next set of cowling mounting holes and re-test. You may have more than one favorite position, for example shield tilted forward on cooler days, and shield tilted back for hot days to let more air to your body.

Please make sure that you do not set the windshield in such a way as to cause your handlebars or hand guards (if installed) to hit the windshield when turning.

Another consideration could be when you have a passenger on board. You do not necessarily have to raise the shield higher up to get the air to clear their head behind you, because this could put the top edge of the shield in your line of sight. Try just tilting the top edge a bit farther forward to deflect the airflow just a little bit higher, and that might be all that is needed. Your passenger will certainly let you know if that works or not!

Warranty

Your MadStad Mounts are warranted for life against manufacturing defects. This does not include cosmetic issues such as paint fading or scratching, nor the rubber well nuts which can wear out over time.

Disclaimer

Neither MadStad Engineering nor its owners shall be liable for any damages, consequential or inconsequential, resulting from the use of our products. Installation of any of our products constitutes acceptance of these terms.

It is the responsibility of the user to make sure all fasteners are tightened securely, the windshield mounted properly and the adjusters tightened snugly before putting the motorcycle in motion. The MadStad mount IS NOT intended to be adjusted while the motorcycle is in motion; you must pull over out of the way of traffic and come to a complete stop before making any adjustments. The user must never place the windshield in such a position as to interfere with the safe and complete movement of the handlebars.

MadStad Engineering, Inc.
20721 US Highway 301
Dade City, FL 33523 U.S.A.

Phone: 352-608-4069

Fax: 352-608-4195

Web Site: <http://www.madstad.com>

Email: support@madstad.com

Thank you for your support, and ride safely!

WINDSHIELD ANGLE GUIDE

Place the back edge (spine) of this booklet against the front surface of the windshield. If the 60° arrow is pointing straight up then the windshield is at a 60 degree angle up from horizontal. This is the mid-point of the angle range which provides the smoothest airflow. Make slight adjustments forward or backward to fine-tune your own best setting.

